

# WHEEL ALIGNMENT

## 2WD

### 1. MAKE FOLLOWING CHECKS AND CORRECT ANY PROBLEMS

- (a) Check the tires for wear and proper inflation.  
Cold tire inflation pressure: See page A-23

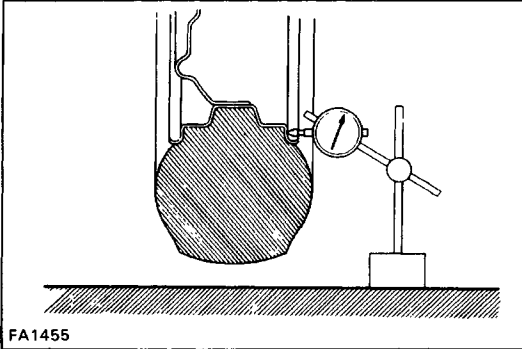

FA1455

- (b) Check the wheel runout.  
Lateral runout: 1.2 mm (0.047 in.) or less
- (c) Check the front wheel bearings for looseness.
- (d) Check the front suspension for looseness.
- (e) Check the steering linkage for looseness.
- (f) Use the standard bounce test to check that the front absorbers work properly.

### 2. MEASURE CHASSIS GROUND CLEARANCE

#### Chassis ground clearance: See page A-23

If the clearance of the vehicle is not standard, try to adjust it by pushing down on the body or by lifting the body. If still not correct, check for bad springs or suspension parts.

**HINT:** Before inspecting wheel alignment, adjust chassis ground clearance to specification.

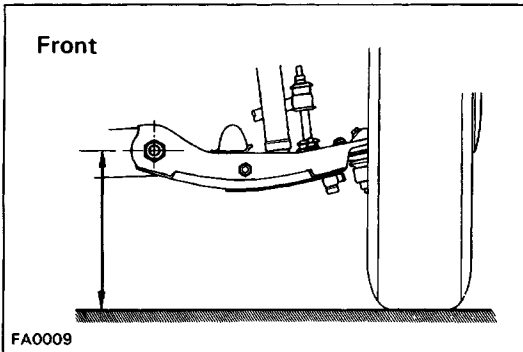

FA0009

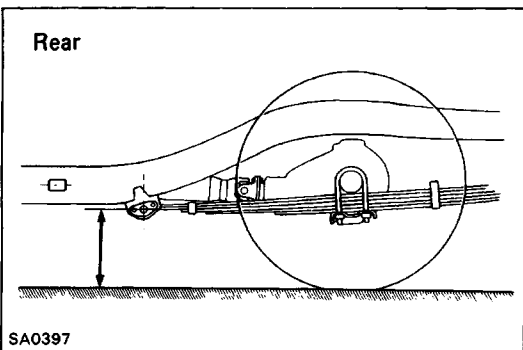

SA0397

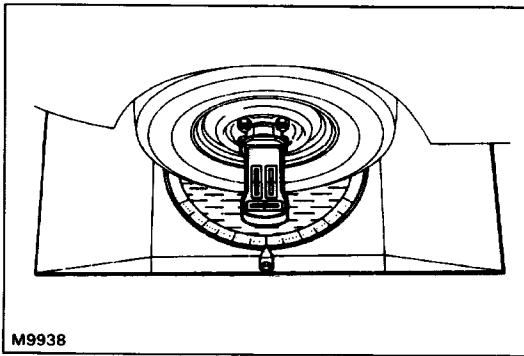

### 3. INSTALL WHEEL ALIGNMENT EQUIPMENT

Follow the specific instructions of the equipment manufacturer.

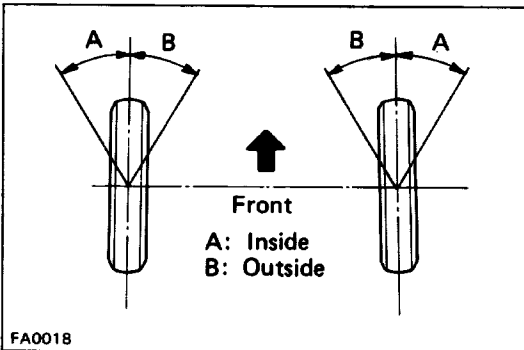

### 4. ADJUST WHEEL ANGLE

Remove the caps of the knuckle stopper bolts and check the steering angles.

**Steering angles: See page A-24**

**HINT:** When the steering wheel is fully turned, make sure that the wheel is not touching the body or brake flexible hose.

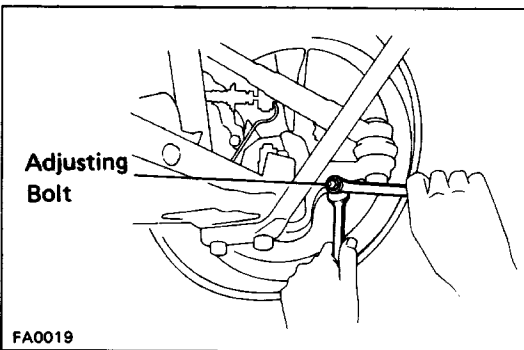

If maximum steering angles differ from standard value, adjust the wheel angle with the knuckle stopper bolts.

**Torque: 34 N-m (350 kgf-cm, 25 ft-lbf)**

If the wheel angle still cannot be adjusted within limits, inspect and replace damaged or worn steering parts.

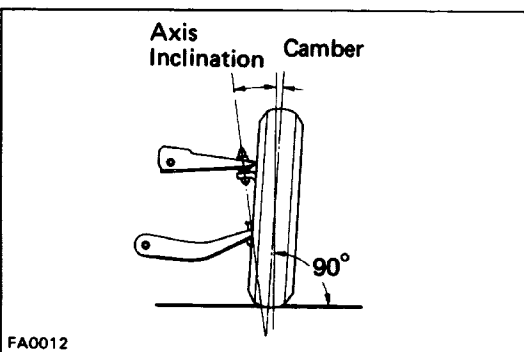

### 5. ADJUST CAMBER, STEERING AXIS INCLINATION AND CASTER

**Specifications: See page A-23, 24**

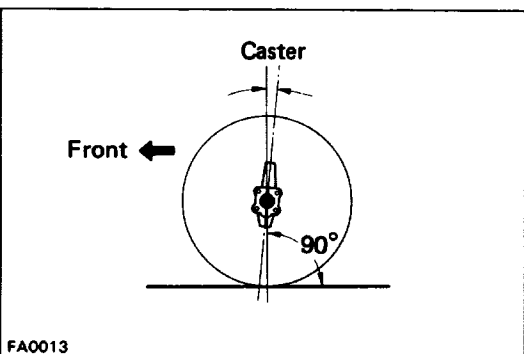

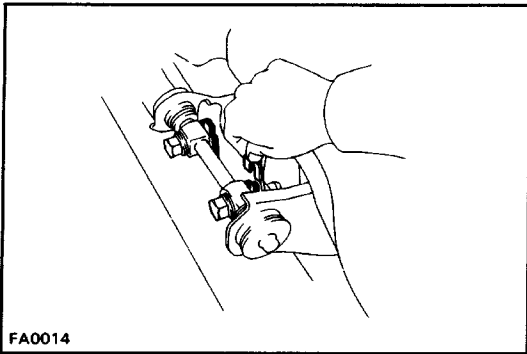

If camber caster is not within specification, adjust by adding or removing shims on the upper arm.

Shim thickness mm (in. )

Thickness	
4.0	(0.157)
1.6	(0.063)
1.2	(0.047)

If the steering axis inclination is not as specified after camber and caster have been correctly adjusted, recheck the steering knuckle and front wheel for bending or looseness.

## 6. INSPECT TOE-IN

**Toe-in: See page A-23**

If toe-in is not within specification adjust by the tie rod end.

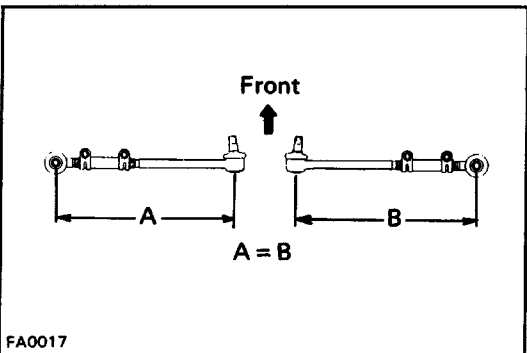
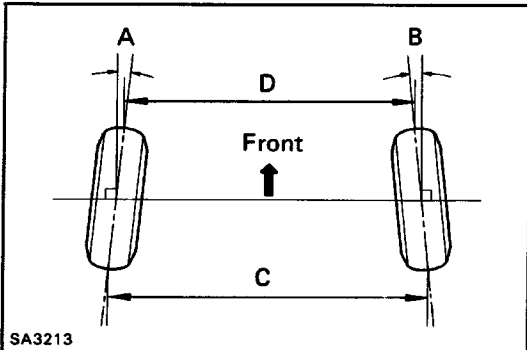

## 7. ADJUST TOE-IN

- Loosen the clamp bolts.
- Adjust toe-in by turning the left and right tie rod tubes an equal amount.

**Toe-in: See page A-23**

HINT: Make sure that the tie rods are the same length.

**Left-right error: 3.0 mm (0.118 in.) or less**

- Tighten the clamp bolts and torque them.

**Torque: 25 N-m (260 kgf-cm, 19 ft-lbf)**

## 8. INSPECT SIDE SLIP (REFERENCE ONLY)

**Side slip: 3.0 mm/m (0.118 in. 13.3 ft) or less**

